

INSTALLATION INSTRUCTIONS AND OWNER'S MANUAL

Outdoor Gas Grill

Bibury Range

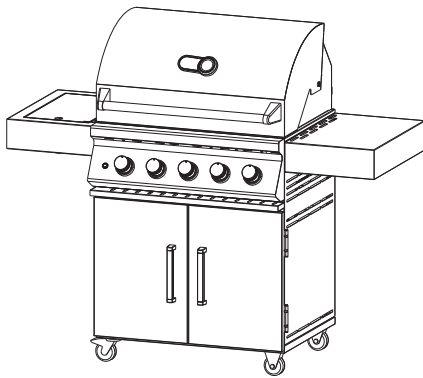

Bibury 3

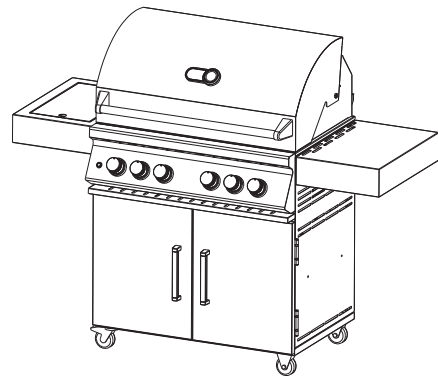

Bibury 4

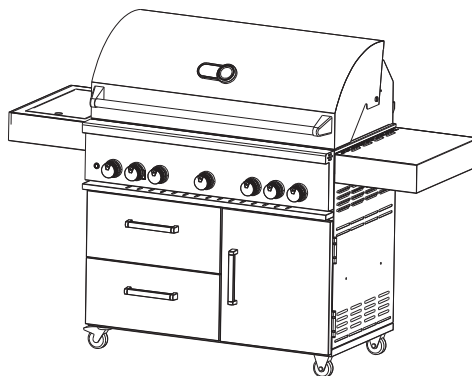

Bibury 5



Use outdoors only, Read the instructions before using this appliance

WARNING: Accessible parts may be very hot. Keep young children away. This appliance must be kept away from flammable materials during use. Do not move the appliance during use. Turn off the gas supply at the gas cylinder after use. Do not modify the appliance.

 **WARNING**

DO:

- DO** Use a spanner to tighten all gas fittings.
- DO** Check all gas hoses and line connections for damage, cuts and cracks each time before using the appliance.
- DO** Always leak test with soapy water.
- DO** Check main burners, side burners and infrared rear burner regularly for insect nests and spiders' webs. Nests and webs are dangerous and need to be fully cleaned.
- DO** Use the appliance outdoors only.
- DO** Remember accessible parts maybe very hot, **ALWAYS KEEP CHILDREN AWAY** from the appliance.
- DO** Have the gas cylinder filled by an authorized gas supplier.
- DO** Always wear protective gloves when handling hot components.
- DO** Close the gas cylinder valve after each use.
- DO** Clean the grease tray regularly.
- DO** Use the grill at least 1.5m away from any wall or surface of combustible material, gasoline, flammable liquids or vapours.
- DO** Turn off the gas supply at the gas cylinder after use.
- DO** Place the gas cylinder outside the appliance when in use.
- DO** Turn off the gas supply at the gas cylinder in the event of a gas leak.

DO NOT:

- DO NOT** Lean over the appliance when lighting.
- DO NOT** Store combustible materials, gasoline or flammable liquids within the vicinity of the appliance.
- DO NOT** Use the appliance with any cover on.
- DO NOT** Use any plastic or glass utensils on the appliance.
- DO NOT** Use the appliance in strong winds.
- DO NOT** Dismantle the control valves.
- DO NOT** Test for a gas leak with a naked flame.
- DO NOT** Store spare gas cylinders in the appliance.
- DO NOT** Lay the gas cylinder down (ALWAYS KEEP UPRIGHT).
- DO NOT** Use the appliance indoors.
- DO NOT** Modify the construction of the appliance, the size of the burners, injector orifice or any other components.
- DO NOT** Move the appliance when in use.
- DO NOT** Obstruct any ventilation on the appliance.
- DO NOT** Allow the flexible gas supply hose or any electrical cord to contact with any heated surface on the appliance.
- DO NOT** Use charcoal or any other solid fuel in this appliance.
- DO NOT** Disconnect any gas fittings while the appliance is in use.
- DO NOT** Use a rusty or damaged gas cylinder or a damaged valve.
- DO NOT** Fill the gas cylinder beyond 80% of the cap.

CONNECTING THE GAS CYLINDER TO THE APPLIANCE



This appliance is only suitable for use with low-pressure butane, propane, or their mixture of gases and fitted with the appropriate low-pressure regulator via a flexible hose.

The appliance is set to operate with:

- * 28-30 mbar regulator with butane gas @ category 13+.
- * 37 mbar regulator with propane gas @ category 13+.
- * 37 mbar regulator with butane, propane or their mixtures @ category 13B/P (37).
- * 30 mbar or 50 mbar regulator with butane, propane or their mixtures @ category 13B/P (30) or category 13B/P (50) respectively.



CAUTION

Only the gas type and gas category listed in the rating label on the appliance can be used with your appliance.

Gas Hose and Gas Regulator

Use only the regulator and hose approved for LP Gas at the correct pressure.

The pressure adjuster should comply with the standard EN16129 and current regulations in the country where it is installed, this may be found at your nearest retailer of the gas items. Refer to the technical data, it is strictly prohibited to use an adjustable pressure regulator.

The life of the regulator is estimated as 10 years. It is recommended that the regulator is changed within 10 years of the date of manufacture or when the national conditions require it.

The type of replaceable hose should meet the standard of EN16436-Class 3.

The hose used must conform to the relevant standard for the country of use. The length of the hose must be 0.7 meters (minimum) and 1.5 meters (maximum). Worn or damaged hose must be replaced. Ensure that the hose is not obstructed, kinked, or in contact with any part of the appliance other than at its connection. It is recommended that the hose is changed within 1 year of the date of manufacture or when the national conditions require it.



WARNING

The appliance is intended to be used with a regulator and hose assembly, if they are not supplied by the manufacturer the user must choose an authorized regulator and gas hose complying with the standards required and the local regulations.

Storage of the Appliance

When the appliance is not in use the storage of the appliance indoors is only permissible if the cylinder is disconnected and removed from the appliance. When the appliance is not to be used for a long period of time it should be stored in a dust free environment and we suggest putting a cover on the appliance to protect it.

Gas Cylinder

The gas cylinder should not be dropped or handled roughly! When the appliance is not in use, the cylinder must be disconnected. Replace the protective cap on the cylinder after disconnecting the cylinder from the appliance the precaution should be taken when changing the gas cylinder that it is carried out away from any ignition source.

Used cylinders must be stored outdoors in an upright position and out of the reach of children. The cylinder must never be stored where temperatures can reach over 50° C. Do not store the cylinder near naked flames, pilot lights or other ignition sources of ignition.

The cylinder max width is 30cm and the max height is 40cm.



The appliance is designed for use with a gas cylinder 13KGS or less than 13KGS. The gas cylinder cannot be placed under the side burner when the side burner is in use.

Connection to the appliance

Before connection, ensure that there is no debris caught in the head of the gas cylinder, regulator, burner and burner parts.

If the hose is replaced it must be secured to the appliance and regulator connections with hose clips.

Disconnect the regulator from the cylinder (according to the directions supplied with the regulator) when the appliance is not in use.

Check for leakage

Make 2-3 fluid ounces of leak detecting solution by mixing one part washing up liquid with 3 parts water.

Ensure the control valve is "OFF" connect the cylinder to the regulator the regulator to the hose and the hose to the appliance, ensure the connections are secure then turn on the gas.

Brush the soapy solution on to the hose and all the joints, if bubbles appear you have a leak which must be rectified before use.

Retest after fixing the fault.

Turn OFF the gas at the cylinder after testing.

If leakage is detected and cannot be rectified, DO NOT attempt to cure the leakage but consult your gas dealer.

LIGHTING YOUR APPLIANCE

WARNING

This appliance is designed for use outdoors, away from any flammable materials.

It is important that there are no overhead obstructions and that there is a minimum distance of 1.5 m from the side or rear of the appliance.

It is important that the ventilation openings of the cylinder compartment are not obstructed.

The appliance must be used on a level, stable, non-flammable surface.

The appliance should be protected from direct draughts and should be positioned or protected against any direct penetration by water (e.g. rain).

Parts sealed by the manufacture or his agent must not be altered by the user.

No modifications should be made to any part of this appliance, repairs and maintenance should only be carried out by a registered service engineer.

DO NOT let children operate or play near the appliance.

DO NOT use charcoal or ceramic briquets in this appliance.

DO NOT light or use the side burner with the lid in a closed position.

DO NOT attempt to light the burners with the lid closed, a build-up of non-ignited gas inside a closed lid is hazardous.

The side burner is designed for a pot/pan with a diameter 180-260mm, the side burner lid cannot be used as a work table, do not put anything on the side burner lid when it is closed.

Lighting Instructions:

1. Read the instructions before lighting.
2. Open the lid and make sure all the knobs are on the OFF (●) Position.
3. Connect the regulator to the gas cylinder, regulator to the hose and the hose to the appliance, Turn the gas supply "ON" at the cylinder. Check with the use of soapy water for any gas leakage between the bottle and the regulator.
4. Push down and turn the control knob anticlockwise to the high position (⚡) a clicking sound is heard until the burner ignites, should the burner not ignite after a few clicks, turn the control knob back to the off position (●) and then repeat the process.
5. Adjust the heat by turning the knob to the High (⚡)/ Low (⚡) position.
6. To light up the other burners, repeat the same process for the adjacent burner and continue in sequence until all the burners are lit.
7. To turn the appliance OFF, turn the cylinder valve or regulator switch to the "OFF" position and then turn all the control knobs on the appliance clockwise to the "OFF" (●) position.

For Match-Lighting:

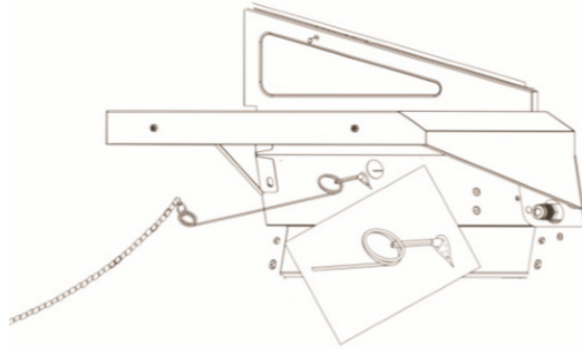

1. To light the main burners by match, place the match into the match holder as in the image and light the match, then put into the lighting hole on the right side of the barbecue, push down and turn the control knob anticlockwise to the high position (🔥) of the burner closest to the match.
2. To light the other burners, take out the cooking grates and place the match near the main burner ports, push down and turn the control knob anticlockwise to the high position (🔥) of the burner closest to the match.
3. To light the side burner by match use the match holder tool as above and place the lit match next to the holes of the side burner head push down and turn the side burner control knob anticlockwise to the High position (🔥) to ignite the gas.
4. If the steps above, don't ignite the burner , Turn off wait 5 minutes and then repeat.

Before cooking on the grill for the first time, light the barbecue turn all the control knobs to high (🔥) make sure all the burners are lit and close the lid for about 15 minutes, this will "heat clean" the internal parts and dissipate any odour from your grill. You may see some colour change of the parts in the cooking area this is natural.

CLEANING AND CARE



WARNING

All cleaning and maintenance should be carried out when the appliance is cool and with the fuel supply turned OFF at the gas cylinder after each use. This appliance designed for use outdoors, away from any flammable materials.

DO NOT Mistake brown or black accumulation of grease and smoke for paint. The interior of the gas appliance is not painted at our factory (and should NEVER be painted). Apply a strong solution of detergent and water or use a grill cleaner with a scrub brush on the insides of the appliance lid and bottom. Rinse and allow to completely air dry.

DO NOT Apply a caustic grill or oven cleaner to painted surfaces.

DO NOT Use abrasive or flammable cleaners as it will damage parts on the appliance and may start a fire.

Plastic parts: Wash with warm soapy water and wipe dry.

Porcelain surfaces: Because of the glass-like composition, most residue can be wiped away with Baking Soda/Water Solution or a specially formulated cleaner. Use nonabrasive scouring powder for stubborn stains.

Painted surfaces: Wash with mild detergent or nonabrasive cleaner and warm soapy water. Wipe dry with a soft nonabrasive cloth.

Stainless Steel Surfaces: Stainless steel would get rust marks if not maintained well. To maintain your appliance's high quality appearance, wash with mild detergent a warm soapy water and wipe dry with a soft nonabrasive cloth after each use. Use stainless steel protection liquid like WD-40 on the surface to avoid rust marks.

Cooking Grids: Use a mild soapy water solution. Non-abrasive scouring powder can be used on stubborn stains then rinse with water.

Cleaning the burner assembly

Follow these instructions to clean and /or replace parts of the burner assembly or if you have trouble igniting the appliance.

- 1 Turn gas off at control knobs and gas cylinder.
- 2 Remove cooking grates, grease tray and grease cup.
- 3 Remove screw at the end of the burner using a screwdriver.
- 4 Carefully lift each burner up and away from the valve openings.
- 5 Wire brush the entire outer surface of the burner to remove food residue and dirt.
- 6 Clean any blocked ports with a stiff piece of wire or an open paperclip.
- 7 Check burners for damage, due to normal wear and corrosion some holes may become enlarged. If any large cracks or holes are found replace the burner.
- 8 Carefully refit burners.
- 9 Replace screw at the end of the burner.
- 10 Replace the grease tray and cooking grates.

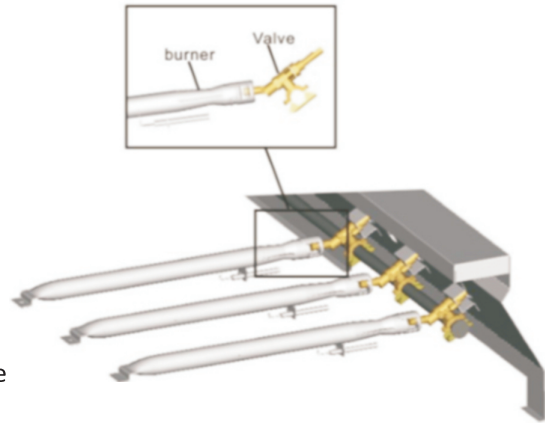

Inspect burner for any damage (cracks or holes).

If damage is found, replace with a new burner. Reinstall the burner, check to ensure that the gas valve orifices are correctly position and secured inside the burner inlet.

We suggest three ways to clean the burner tubes, use the one that is easiest for you.

- (A) Bend a stiff wire into a small hook (a light weight coat hanger works well). Run the hook through each burner tube and burner several times.
- (B) Use a narrow bottle brush with a flexible handle (Do not use a brass wire brush), run the brush through each burner tube and burner several times.
- (C) Wear eye protection: Use an air hose to force air into the burner tube and out of the air ports. Check each port to make sure air comes out of each hole.



CAUTION

NATURAL HAZARDS SPIDERS

FACT: Sometimes spiders and other insects climb into the grill tubes attached to the burners. The spiders spin webs build nests and lay eggs. The webs or the nests can be very small, but they are very strong and can block the flow of gas. Clean burners prior to use after storing or at the beginning of the season or after a period of one month after not been used.







Spider guards are on the air intakes to reduce this problem, but it will not eliminate it! An obstruction can result in a flashback (a fire in the burner tubes). The grill may still light, but the obstruction does not allow full gas flow to the burners.

TROUBLE SHOOTING



Problem	Possible Cause	Prevention/Solution
Burner(s) will not light.	* No gas flow.	* Check to see if LP tank is empty.
	* Coupling nut and regulator not fully connected.	* Turn the coupling nut about one-half to three quarters additional turns, stop when solid. Tighten by hand only- do not use tools.
	* Obstruction of gas flow.	* Clear burner tube(s).
	* Disengagement of burner to valve.	* Reengage burner and valve.
	* Is the appliance assembled correctly?	* Check steps in assembly instructions.
Sudden drop in gas flow or low flame.	* Out of gas.	* Check for gas in LP tank.
	* Excess flow valve tripped.	* Turn off knobs, wait 30 seconds and light appliance. If flames are still low, turn off knobs and LP tank valve. Disconnect regulator. Reconnect regulator and leak test. Turn on LP tank valve, wait 30 seconds and light the appliance.
Flames blow out.	* High or gusting winds.	* Turn front of grill to face wind or increase flame height.
	* Low on LP gas.	* Refill LP Tank.
	* Excess flow valve tripped.	* Refer to "Sudden Drop in gas flow" above.
Flare-up.	* Grease build-up.	* Clean grill.
	* Excessive fat in meat.	* Trim fat from meat before grilling.
	* Excessive cooking temperature.	* Adjust (Lower) temperature accordingly.
Persistent grease fire.	* Grease trapped by food build-up around burner system.	* Turn knobs to OFF. Turn gas off at LP tank. Leave lid in position and let fire burn out. After grill cools, remove and clean all parts.
Flashback (Fire in burner tube(s)).	* Burner and/or burner tubes are blocked.	* Turn knobs to OFF. Clean burner and/or burner tubes.

TECHNICAL INFORMATION

 0063/23 Cadero Identification code: 0063CT7402		 WARNING *Use outdoors only. *Read the instructions before using the appliance. *WARNING: accessible parts may be very hot. Keep young children away. *This appliance must be kept away from flammable materials during use. *Do not move the appliance during use. *Turn off the gas supply at the gas cylinder after use. *Do not modify the appliance.		
Appliance Name	Outdoor Use Gas Grill.		Serial No.	
Model No.	CBF3DD-I		Whistler Bibury 3 Freestanding Gas Grill.	
Appliance Category	I3+(28-30/37)		I3B/P(30)	I3B/P(50)
Type of gas	Butane	Propane	Butane,Propane or their mixture.	Butane,Propane or their mixture.
Gas Pressure	28-30mbar	37mbar	30mbar	50mbar
Total Heat Input (Hs)	20.22 kW		20.22 kW	20.22 kW
Gas consumption	1473 g/h		1459 g/h	1473 g/h
Injector	Main grill	1 mm	1 mm	0.88 mm
	Side grill	0.89 mm	0.89 mm	0.79 mm
	Back grill	0.89 mm	0.89 mm	0.79 mm

 0063/23 Cadero Identification code: 0063CT7402		 WARNING *Use outdoors only. *Read the instructions before using the appliance. *WARNING: accessible parts may be very hot. Keep young children away. *This appliance must be kept away from flammable materials during use. *Do not move the appliance during use. *Turn off the gas supply at the gas cylinder after use. *Do not modify the appliance.		
Appliance Name	Outdoor Use Gas Grill.		Serial No.	
Model No.	CBF4DD-I		Whistler Bibury 4 Freestanding Gas Grill.	
Appliance Category	I3+(28-30/37)		I3B/P(30)	I3B/P(50)
Type of gas	Butane	Propane	Butane,Propane or their mixture.	Butane,Propane or their mixture.
Gas Pressure	28-30mbar	37mbar	30mbar	50mbar
Total Heat Input (Hs)	25.5 kW		25.5 kW	25.5 kW
Gas consumption	1858 g/h		1840 g/h	1858 g/h
Injector	Main grill	1 mm	1 mm	0.88 mm
	Side grill	0.89 mm	0.89 mm	0.79 mm
	Back grill	1 mm	1 mm	0.88 mm

TECHNICAL INFORMATION

		 WARNING		
0063/23 Cadero Identification code: 0063CT7402		*Use outdoors only. *Read the instructions before using the appliance. *WARNING: accessible parts may be very hot. Keep young children away. *This appliance must be kept away from flammable materials during use. *Do not move the appliance during use. *Turn off the gas supply at the gas cylinder after use. *Do not modify the appliance.		
Appliance Name	Outdoor Use Gas Grill.		Serial No.	
Model No.	CBF500CDC-I		Whistler Bibury 5 Freestanding Gas Grill.	
Appliance Category	I3+(28-30/37)		I3B/P(30)	I3B/P(50)
Type of gas	Butane	Propane	Butane,Propane or their mixture.	Butane,Propane or their mixture.
Gas Pressure	28-30mbar	37mbar	30mbar	50mbar
Total Heat Input (Hs)	29.9 kW		29.9 kW	29.9 kW
Gas consumption	2178 g/h		2158 g/h	2178 g/h
Injector	Main grill	1 mm	1 mm	0.88 mm
	Side grill	0.89 mm	0.89 mm	0.79 mm
	Back grill	1 mm	1 mm	0.88 mm

REPLACEMENT PARTS LIST

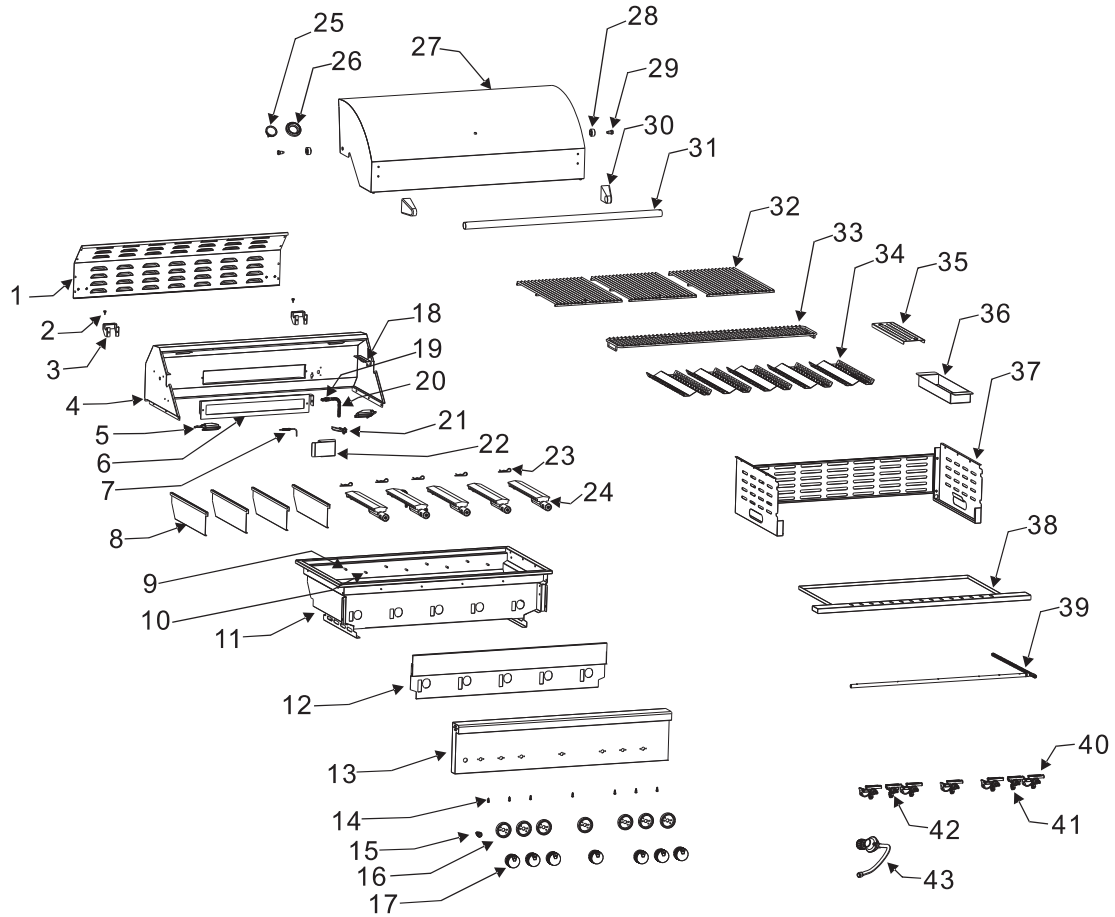

REF #	DESCRIPTION	QUANTITY	REF #	DESCRIPTION	QUANTITY
1	REAR LID COVER	1	23	COTTER PIN	5
2	ROTISSERIE ROD HOLDER (optional)	2	24	CAST STAINLESS STEEL BURNER	5
3	RUBBER	2	25	TEMPERATURE GAUGE	1
4	LID - REAR	1	26	TEMPERATURE GAUGE SEAT	1
5	HALOGEN LIGHT	2	27	LID - FRONT	1
6	REAR BURNER	1	28	LID AXLE SLEEVE	2
7	THERMOCOUPLE	1	29	LID AXLE	2
8	HEAT DIVIDER (optional)	4	30	LID HANDLE END CAP	2
9	HEAT DIVIDER SUPPORTING PIN	8	31	LID HANDLE	1
10	FLAME TAMER SUPPORTING PIN	5	32	COOKING GRATE	3
11	FIRE BOX ASSEMBLY	1	33	WARMING RACK	1
12	INSULATION PANEL	1	34	FLAME TAMER	5
13	CONTROL PANEL	1	35	SMOKER LID (optional)	1
14	LED LIGHT	7	36	SMOKER (optional)	1
15	LIGHT SWITCH	1	37	EXTERNAL INSULATION ASSEMBLY	3
16	KNOB SEAT	7	38	GREASE PAN	1
17	KNOB	7	39	MANIFOLD	1
18	WARMING RACK HOLDER	2	40	MAIN BURNER GAS VALVE	5
19	REAR BURNER ORIFICE	1	41	REAR BURNER GAS VALVE	1
20	STAINLESS FLEX TUBE	1	42	SIDE BURNER GAS VALVE	1
21	REAR BURNER IGNITER	1	43	LP REGULATOR	1
22	REAR BURNER IGNITER BOX	1			

FOR CART MODEL ONLY

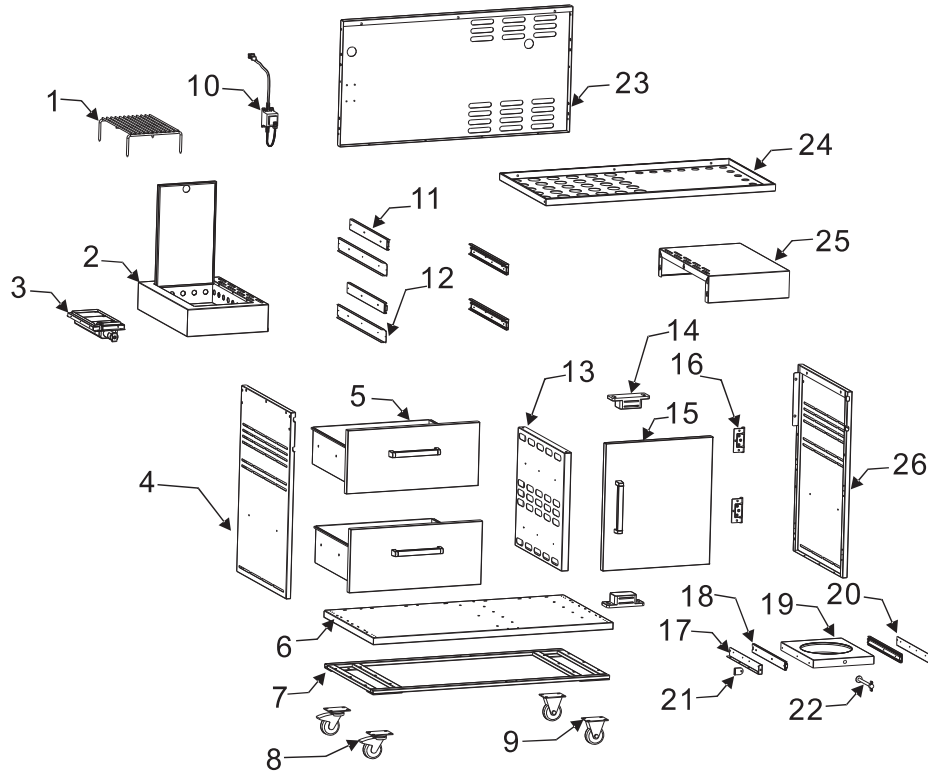

REF #	DESCRIPTION	QUANTITY	REF #	DESCRIPTION	QUANTITY
1	STAINLESS STEEL SIDE COOKONG GRID	1	14	MAGNET	2
2	INFRARED SIDE BURNER	1	15	DOOR	1
3	INFRARED SIDE BURNER	1	16	HINGE	2
4	LEFT PANEL	1	17	GAS BOTTLE HOLDER SLIDES LEFT SUPPORT	1
5	DRAWER	2	18	GAS BOTTLE HOLDER SLIDE	2
6	BOTTOM PANEL	1	19	GAS BOTTLE HOLDER	1
7	BOTTOM FRAME	1	20	GAS BOTTLE HOLDER SLIDES RIGHT SUPPORT	1
8	UNIVERSAL WHEEL	2	21	SLIDES LOCK	1
9	WHEEL	2	22	GAS BOTTLE LOCK	1
10	TRANSFORMER	1	23	REAR PANEL	1
11	DAMPING SLIDE	4	24	TOP PANEL	1
12	DRAWER SLIDES SUPPORT	2	25	RIGHT SIDE TABLE	1
13	MIDDLE DIVIDER	1	26	RIGHT PANEL	1

ASSEMBLY INSTRUCTIONS

Tools Needed: A Phillips screwdriver, a wrench comes with this product

Whistler Bibury with Infrared side burner

IMPORTANT: TO PROPERLY ALIGN FRAME AND DOORS,
ASSEMBLY GRILL ON A FLAT AND LEVEL SURFACE.

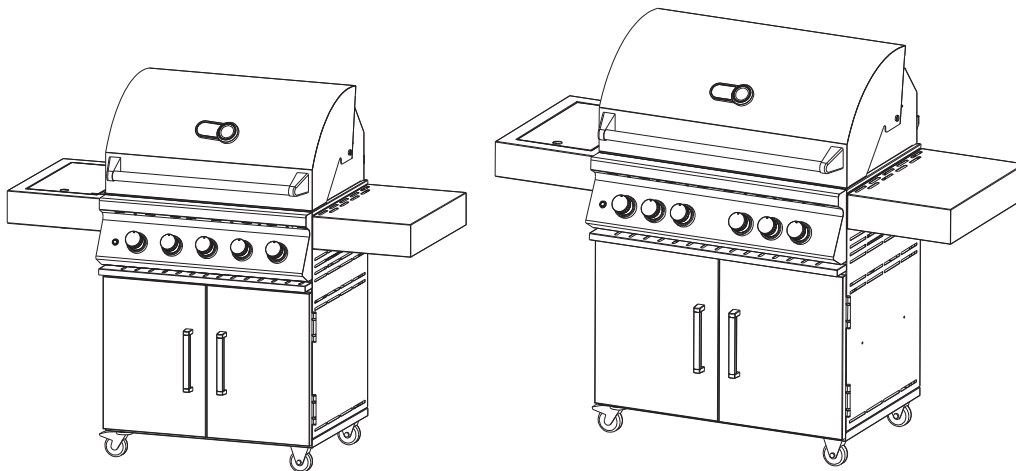

Bibury 3

Bibury 4



Bibury 5

ASSEMBLY STEPS

1

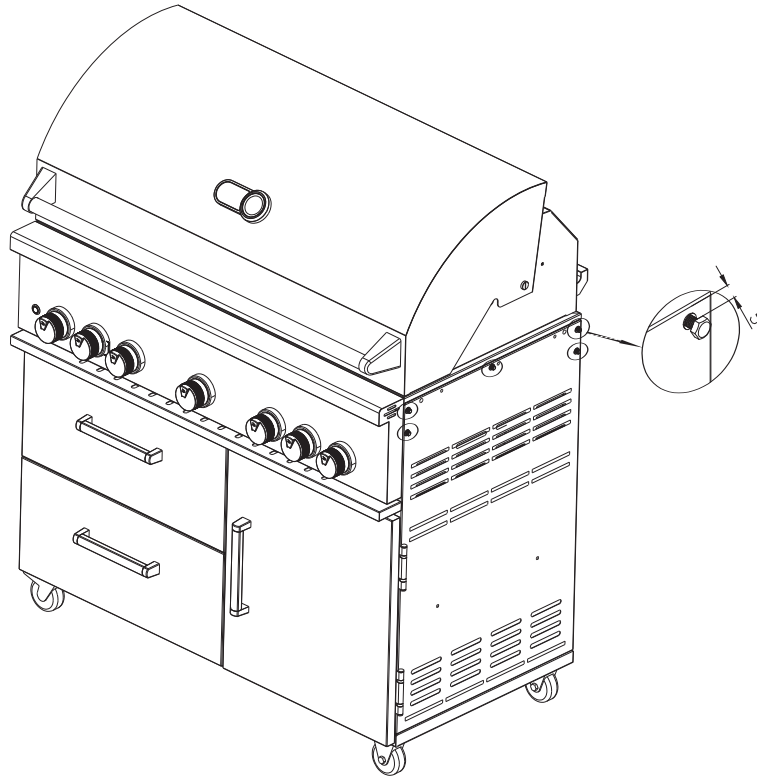

 Screw M6*12 10PCS

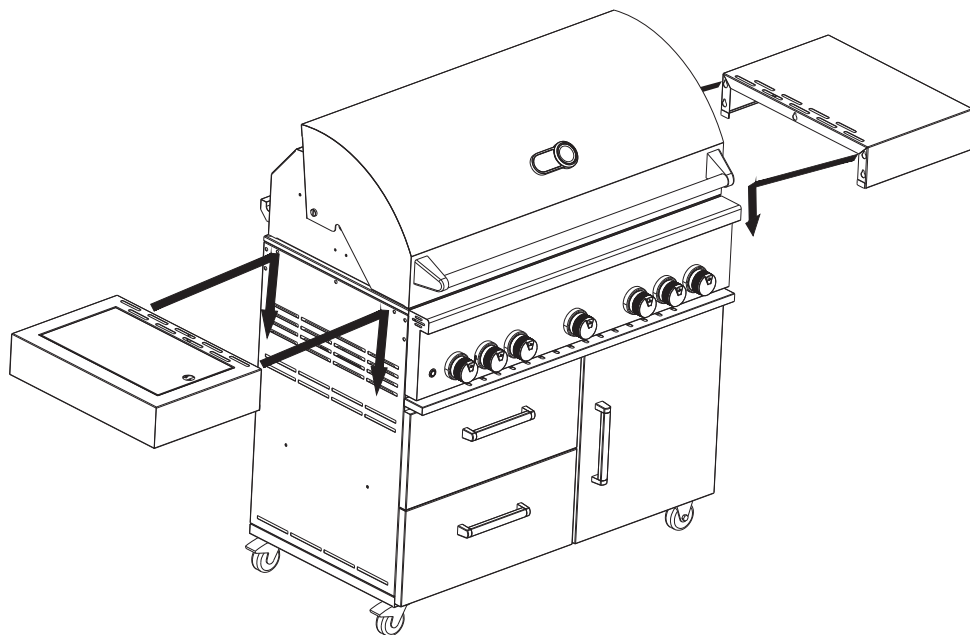

ASSEMBLY STEPS

2

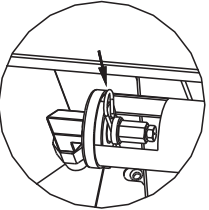
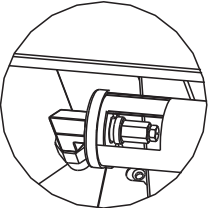
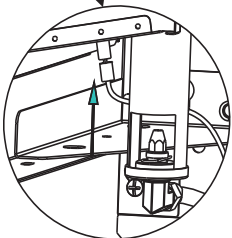
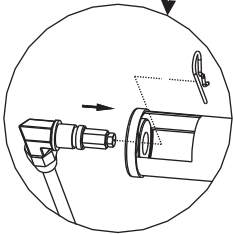
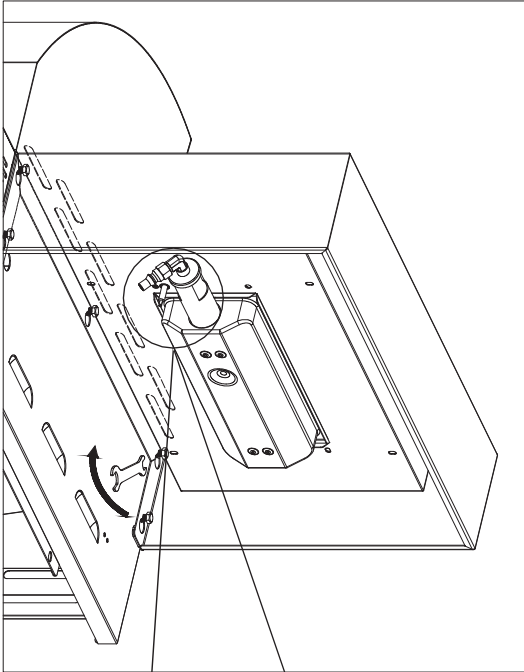

 1PCS

ASSEMBLY STEPS

3

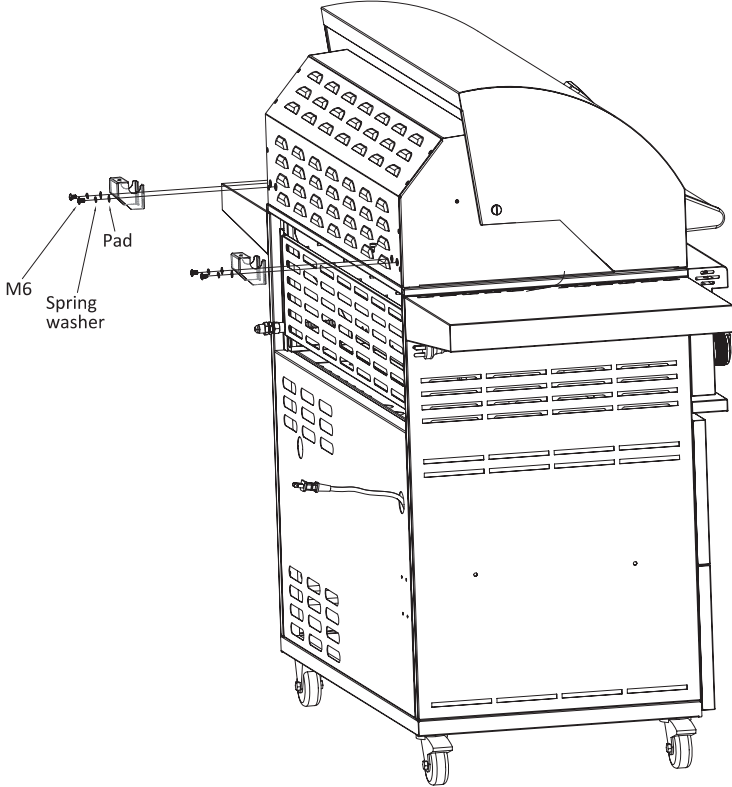

ASSEMBLY STEPS

CONNECTING TO GAS SOURCE

Refer to the following instructions and illustrations for typical gas supply connections. We strongly suggest professional installation and hook-up of the Gas BBQ.

IMPORTANT: Before connecting grill to gas source, make sure BBQ Grill control knobs are in “OFF” position.

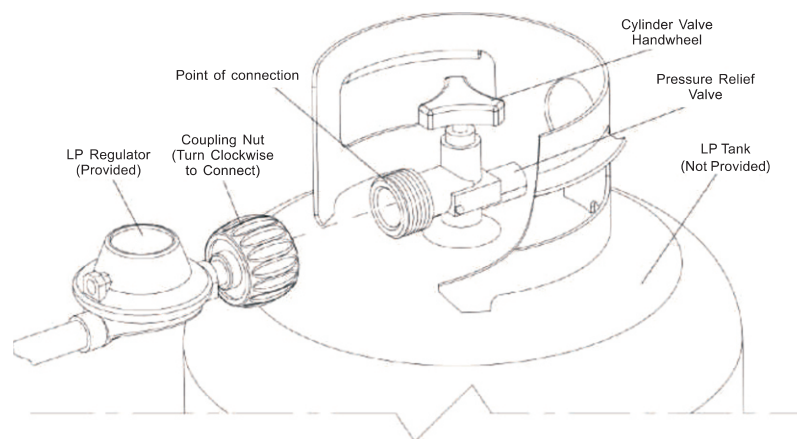

LP Gas cylinder and Regulator connections differ from country to country

LP GAS CONNECTIONS

- The LP gas pressure regulator and hose assembly supplied with this unit must be used without alteration.
- Make sure the tank is firmly secured in an upright position.
- Make sure the valve on the tank is turned off.
- Turn the black coupling nut of the hose and regulator assembly in a clockwise direction.
- Make sure it is completely threaded onto the cylinder valve before turning gas supply on.

ASSEMBLY STEPS

- Remove plastic cap from the pipe at the back of the grill.
- Attach the other end of flex line to shut-off valve through a nipple.
- Attach a shut-off valve to gas supply pipe.

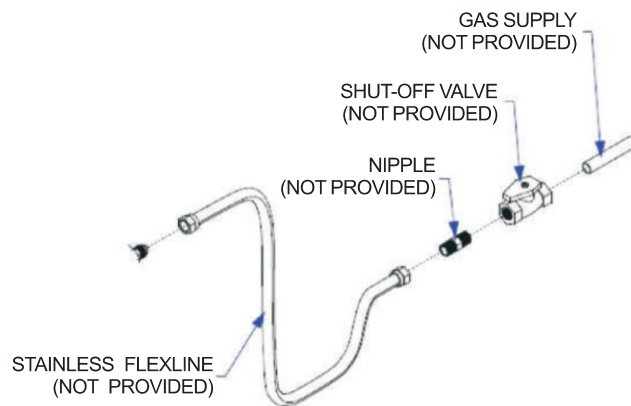

CHECKING FOR GAS LEAKS

Prior to the first use and at the beginning of each new season (or, if using LP, whenever gas cylinder is changed), it is a must that you check for gas leaks. Follow these steps:

WARNING:
NEVER TEST FOR GAS LEAKS
WHILE THE GRILL IS LIT!

1. Make a soap solution by mixing one part liquid detergent and one part water.
2. Turn off heat control valve(s), and then turn on gas at source.
3. Apply the soap solution to all gas connections: bubbles will appear in the soap solution if connections are not properly sealed. Tighten or repair as necessary.
4. If you have a gas leak that you cannot repair, turn off the gas at the source, disconnect fuel line from the grill and immediately call your grill dealer and gas supplier for professional assistance.

ASSEMBLY STEPS

PLACEMENT OF YOUR GRILL

The control panel **MUST** remain removable for service.

ENSURE PROPER COMBUSTION AIR AND COOLING AIRFLOW

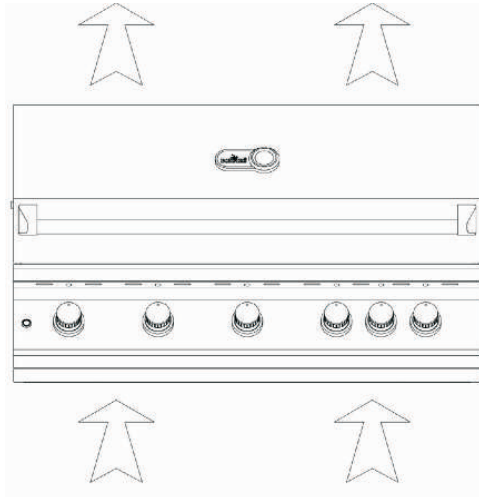

Maintain proper ventilation airflow

Proper airflow **MUST** be maintained for the grill to perform as it was designed. If airflow is blocked, overheating or poor combustion will result. Do not block the 1" (2.5 cm) front air inlet along the bottom of the control panel or more than 75% of the cooking grid surface with pans or griddles.

Note: The 1" (2.5 cm) front air space also allows access to the drip tray.

CORRECT

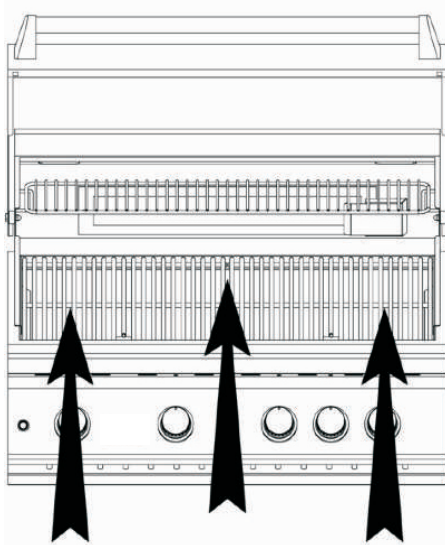

Place grill so prevailing wind blows toward front of grill.

INCORRECT

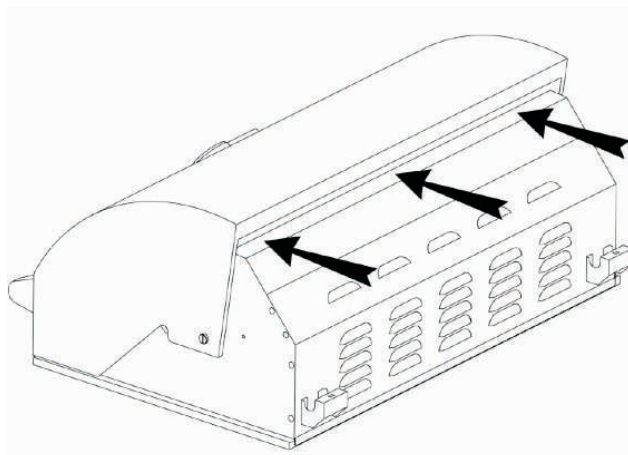

You **MUST** protect rear grill vent from prevailing wind.

ASSEMBLY STEPS

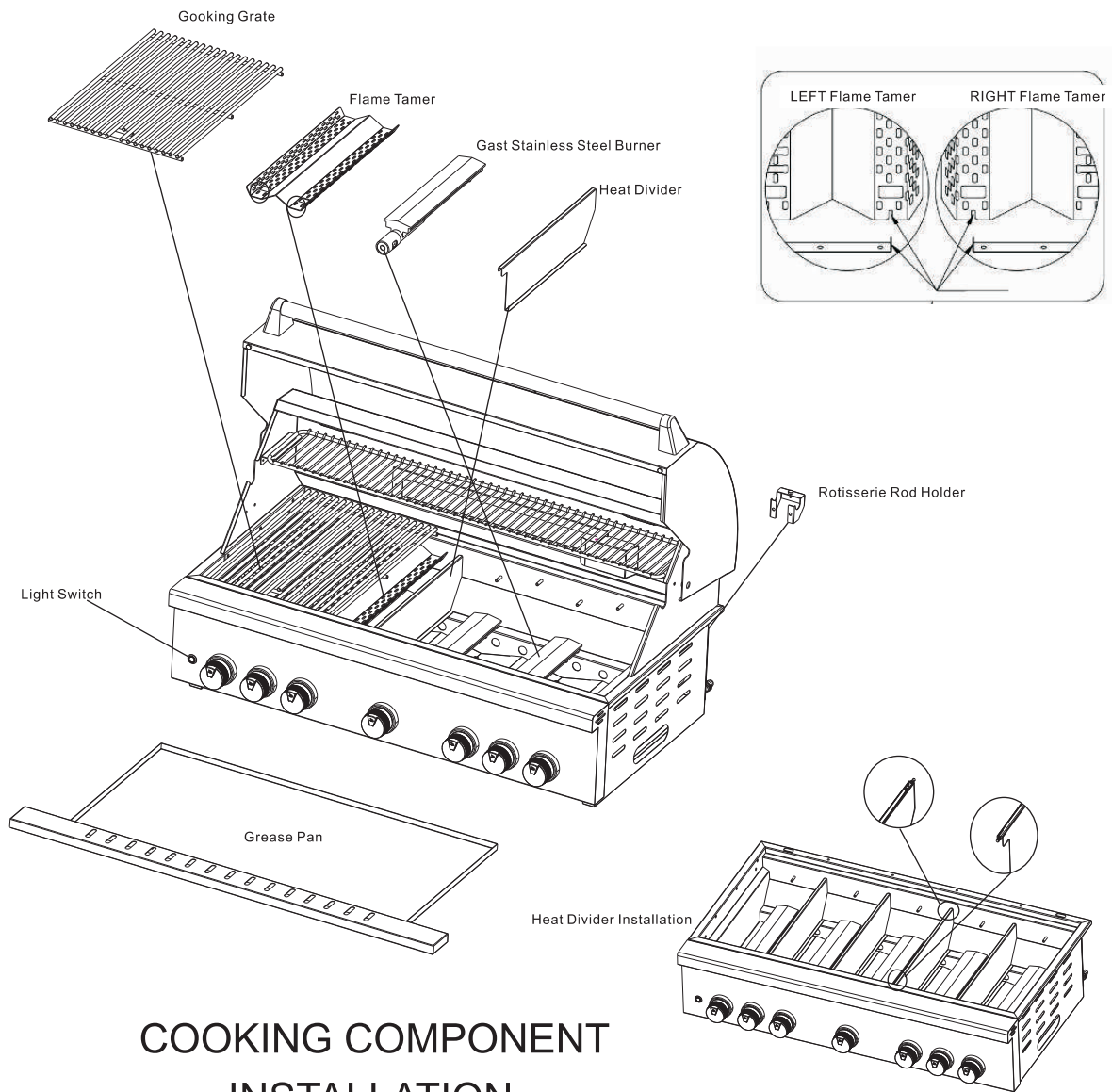

COOKING COMPONENT INSTALLATION

1. Place stainless steel flame tamers on lower ledge above burners in grill insert. See diagram above for detail of the LEFT and RIGHT flame tamers installation.
2. Place cooking grids in grill insert on ledge above flame tamers.
3. Install the rotisserie rod holder with the screws provided with the grill. Two screws on each holder.

NOW YOUR GRILL IS READY TO USE!

LIGHTING AND OPERATING INSTRUCTIONS

LIGHTING PROCEDURES

Main burner(s):

1. Become familiar with the safety guidelines at the front of the manual.

2. If your grill fuel source is a LP gas cylinder, check to see that cylinder is filled.

3. Check that the end of each burner tube is properly located over each valve orifice .

4. Make sure all gas connections are securely tightened.

5. Always open lid before lighting.

6. Set ALL BBQ Grill control knobs to “OFF” and open gas supply.

7. Ignite only the burners you intend to use, using the same method for each: Push in control knob completely and rotate slowly (3 to 4 seconds) about 1/4 turn to the left (counter clockwise) until a click is heard. The 3 to 4 second duration should provide enough gas to light the burner. If the burner does not light, immediately return the control knob to “OFF” , wait several minutes for the gas to disperse, and repeat the process. After burner ignites, repeat procedure with any other burner needed.

8. Adjust control knob(s) to desired cooking temperature.

NOTE: If igniters fail to produce a spark at the electrode tip, burners can be manually lit with a fireplace-type match.

NOTE: To light gas grill with a-type match, follow steps 1 through 6 above.

Remove cooking grid and flame tamer from burner you wish to light. Insert lighted match or long-necked butane lighter placing flame near to burner ports.

Press in control knob and rotate left to “HIGH” setting to release gas. Burner should light immediately. If more than one burner is needed, repeat procedure with each burner.

Replace flame tamer and cooking grid. Turn off burners not needed, and adjust other burners to desired cooking temperature.

WARNING:

Do not smoke while lighting grill or checking gas supply connections!

CAUTION:

Test for leaks with a soap solution, never with a flame . See instructions in the "Checking For Gas Leaks?"

Rear burner (roisserie burner):

The rear infrared rotisserie burner allows for slow rotisserie cooking of meats and poultry. Infrared burners radiate heat onto the outer surface of the food.

1. Always open lid before lighting.
2. Set ALL BBQ Grill control knobs to "OFF" and open gas supply.

3. Push in control knob completely and rotate slowly (5 to 10 seconds) about 1/4 turn to the left (counter clockwise) until a click is heard. The 5 to 10 second duration should provide enough gas to light the burner.

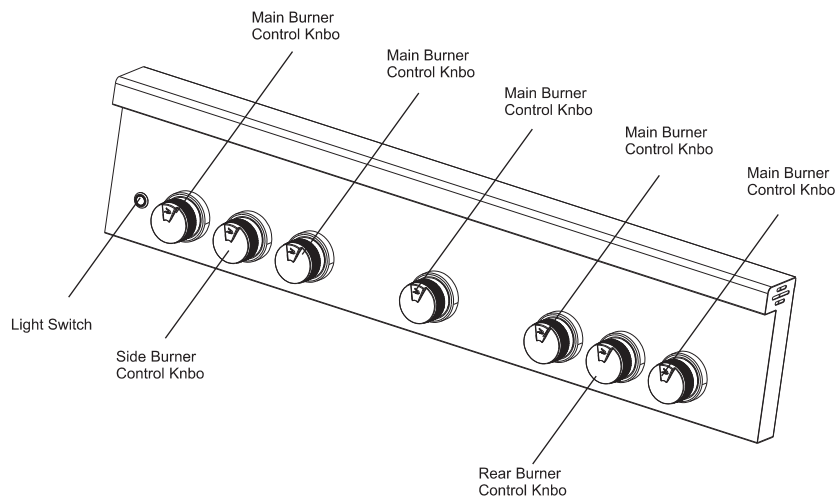

Continue pressing the knob for 5 seconds when the burner lights. If the burner does not light, immediately return the control knob to "OFF" wait several minutes for any accumulated gas to clear out of the grill.

4. Keep lid closed and operate burner at the "ON" position when using rotisserie.

NOTE: Rotisserie burner may take a few tries to ignite.

The uk atmosphere can mean a little more patience is required due to the dampness in the air.



**NEVER OPERATE ROTISSERIE BURNER WITH MAIN BURNER(S) "ON"
WARMING RACK MUST BE REMOVED WHEN OPERATING THE ROTISSERIE BURNER .**

Do not attempt to regulate the rotisserie burner by using the control knob. This control has a fixed setting and is not adjustable.

NOTE: Initially, the Ceramic Panel will have a blue flame that, after some time, will change to an orange flame and the Ceramic Panel will glow an orange colour. This may not be evident in bright daylight.

To light Rotisserie Burner with a fireplace-type match, follow steps 1 & 2 above. Carefully insert lighted fireplace-type match or long-necked butane lighter placing flame near to the Ceramic Panel. Press in control knob and rotate left (counter clockwise) to “HIGH” or “ON” setting to release gas. Burner should light immediately.

OPERATING PROCEDURE

Burn-off: Before cooking on your gas grill for the first time, burn the grill to get rid of any odors or foreign matter by igniting the burners, closing the lid, and operating at “HIGH” setting for about five minutes. You may then either set the controls to “OFF” or cook on your grill immediately by turning the control knobs to a lower setting.



DO NOT LEAVE THE GRILL UNATTENDED WHILE IN USE

Preheating: It is necessary to preheat the grill for a short time before cooking certain foods, depending on the type of food and the cooking temperature. Food that requires a high cooking temperature needs preheat for five minutes; food that requires a lower cooking temperature needs only a period of two to three minutes. There is no need to preheat for casseroles or other foods that require slow cooking.

COOKING TEMPERATURES

HIGH setting: Use this setting only for fast warm-up, for searing steaks and chops, and for burning food residue from the cooking grids after the cookout is over.

MEDIUM setting: Use this setting for most grilling, roasting or baking, and for cooking hamburgers and vegetables.

LOW setting: Use this setting for all smoker cooking, rotisserie cooking, and when cooking very lean cuts such as fish.

NOTE: These temperatures vary with the outside temperature and the amount of wind.

Cooking With Indirect Heat: You can cook poultry and large cuts of meat slowly to perfection on one side of the grill by indirect heat from the next burner. The heat from the lighted burner circulates gently throughout the grill, cooking the meat or poultry without any direct flame beneath or below the food you are preparing. This method greatly reduces flare-ups when cooking extra fatty cuts, because there is no direct flame to ignite the fats and juices that drip down during cooking. Place a drip pan slightly smaller than the cut of meat on the cooking grids or flame tamer surface under the meat being cooked. This will allow you to catch meat juices for making gravy.

Flare-Ups: The fats and juices that drip from the meat cause flare-ups. Since flare-ups impart the distinctive taste and colour for food cooked over an open flame, they should be expected and encouraged within reason. Nevertheless, uncontrolled flaring can result in a ruined meal. To control excessive flare-ups caused by too high a heat setting, turn the heat control knob to a lower setting.

CAUTION:

If burners go out during operation, close gas supply at source, and turn all gas valves off. Open lid and wait five minutes before attempting to re-light (this allows accumulated gas fumes to clear).

CAUTION:

Should a grease fire occur, close gas supply at source, turn off all burners and leave lid closed until fire is out. Do not use water or any liquid to extinguish a grease fire.

WARNING:

Do not attempt to disconnect any gas fitting while your barbecue is in operation or while gas feed is on.

ROTISSERIE COOKING

Rotisserie is mostly used to cook large pieces of meat and poultry to assure slow, even cooking. The constant turning provides a self-basting action, making food cooked on a rotisserie exceptionally moist and juicy. Rotisserie cooking generally requires 1 1/2 to 4 1/2 hrs to cook depending on the size and type of meat being cooked. You can have rotisserie cooking with indirect heat as shown or with infrared rotisserie burner.

For successful rotisserie, the meat should be centered and balanced as evenly as possible on the spit rod to avoid overworking the rotisserie motor (see rotisserie kit assembly shown below).

Since indirect heat is often used in cooking on a rotisserie, a foil or aluminum drip pan is advisable to prevent excessive flare-ups. Generally, the cooking grates are removed to allow for the swing of the rotisserie. A basting pan is placed under the rotisserie area on top of the flame tamer(s) to catch the drippings.

Rotisseries set option

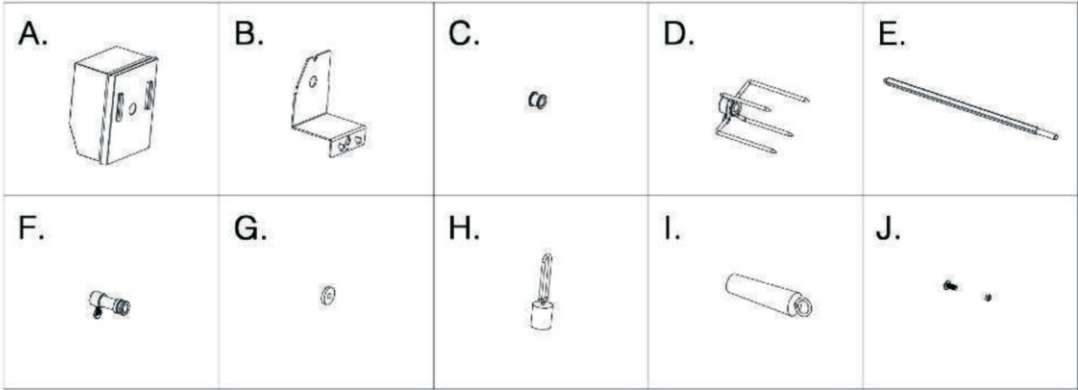
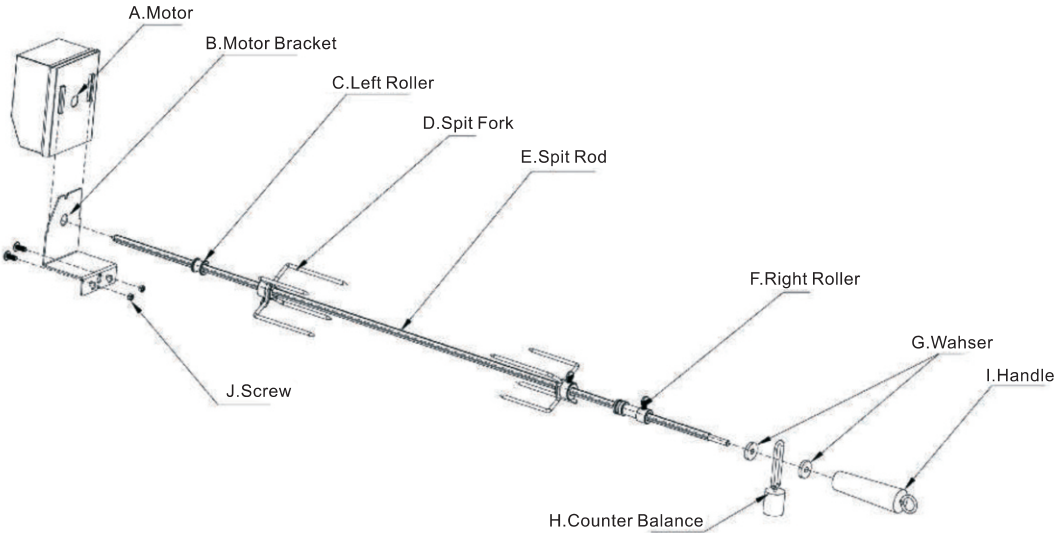

ITEM	DESCRIPTION	QTY	ITEM	DESCRIPTION	QTY
A	240V MOTOR W/SWITCH	1	F	RIGHT ROLLER	1
B	MOTOR MOUNT BRACKET	1	G	WASHER	2
C	LEFT ROLLER	1	H	COUNTER BALANCE	1
D	SPIT FORK	2	I	HANDLE	1
E	SPIT ROD	1	J	BRACKET SCREW	2

Attach the bracket to the left side of the grill as shown below by passing two bolts

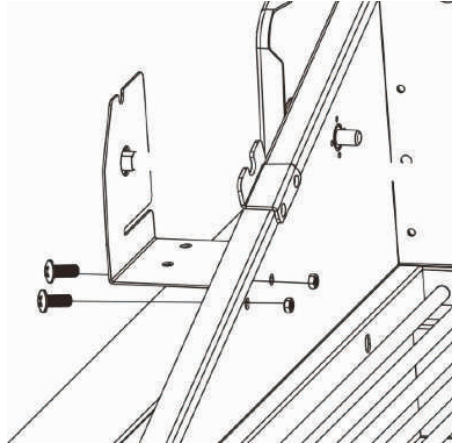

through the bracket. Place a washer on the end of each bolt. Secure bolts with nuts. Take care not to over tighten the bolts. Then slide the rotisserie motor onto the bracket.

The meat should be centered and balanced as evenly as possible on the spit rod to avoid overworking the motor.

To adjust the counter-weight, loosen the washer and adjust the counter-weight to properly position the weight of the food being cooked.

Since indirect heat is often used in cooking on a rotisserie, a foil or aluminum drip pan is advisable to prevent excessive flare-ups. If more space is needed when using the rotisserie, remove the cooking grates and place the drip pan on the flame tamers. You may wish to add beer, wine or water to pan.

It is advisable to load rotisserie with meat to be cooked before turning on gas to check to see that the spit rod is turning properly without any unnecessary strain on the motor. Then light infrared burner.



Remark:
Motor mounting may
differ slightly!

INSPECTING / CLEANING BURNERS AND GAS VALVE ORIFICES

By following these cleaning procedures on a timely basis, your grill will be kept clean and working properly with minimum effort.

CAUTION:
Always turn off the gas supply prior to cleaning your grill and make sure the grill is not hot.

BURNER CLEANING

1. Remove burner from the grill insert (See picture below). Bend a stiff wire (a paper clip is ideal) into a small hook as shown below. Run the hook through each burner ports and burner several times.

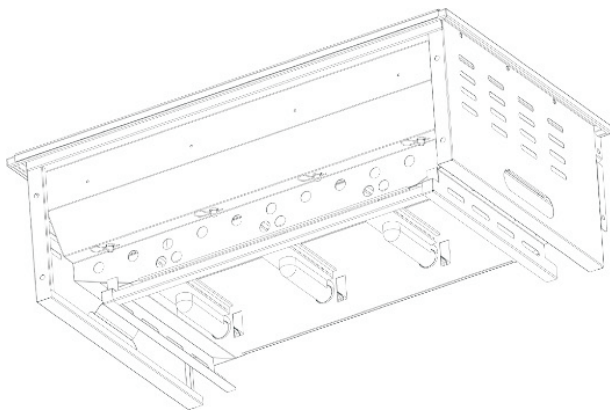

REMOVE COTTER PIN FROM CAST PEG BEFORE LIFTING UP THE BURNER

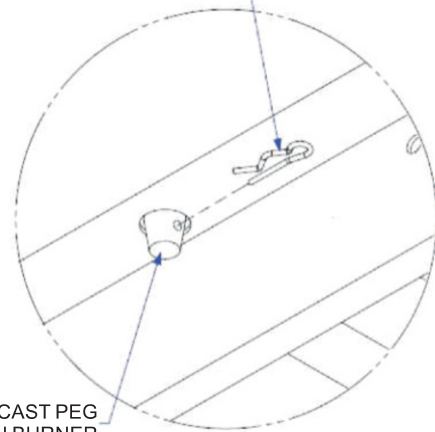

2. Wire brush entire outside surface of burner to remove loose corrosion.
3. Clean any clogged hole with a stiff wire (such as an open paper clip).
4. Inspect the burner assembly for any openings caused by corrosion.

BURNER SHUTTER CLIP INSPECTION / ADJUSTMENT

The burners are set to a factory setting; however the air to fuel mixture may need to be adjusted to accommodate different gas pressures. In order to adjust the air to fuel mixture, loosen the screw and rotate the shutter clip to the appropriate setting (see diagrams below). Tighten the screw and repeat adjustment procedure to the remaining burners. This should improve burner efficiency.

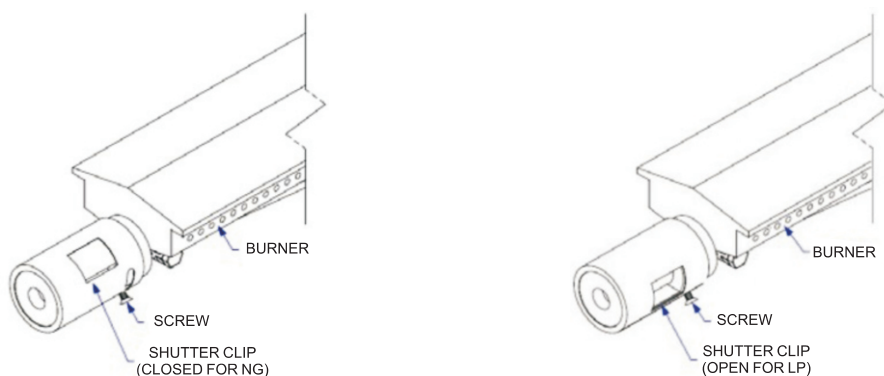

BURNER REPLACEMENT INTO INSERT

CAUTION:
Always turn off the gas supply prior to clearing your grill.

1. Replace burner back into the grill insert. There is no need to replace the cotter pin back into the cast peg, it is for shipping purposes only.

2. Check the burner for proper location after replacing. Make sure the valve orifices are inside of the burner tubes. If the valve orifices do not fit inside the burner tubes, lighting the burners may cause explosion and/or fire.

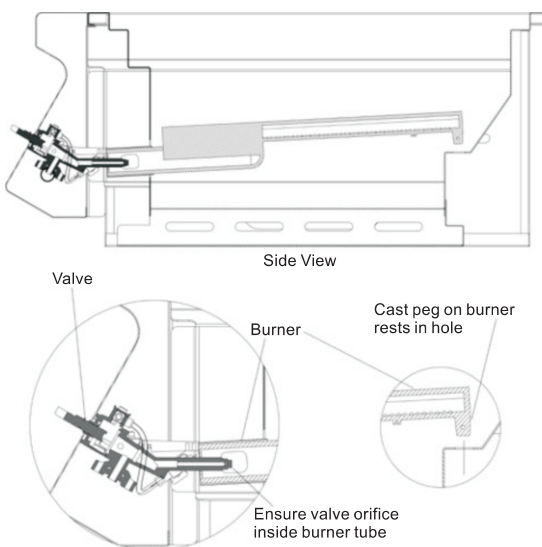

IGNITOR / ELECTRODE CHECK

With all control knobs set to “OFF” check each igniter individually for presence of spark at electrode. In turn, push each control knob in fully and turn slowly about a 1/4 turn to the left (counter-clockwise) until a click is heard; the trigger hitting the strike block should produce a blue spark at the electrode tip. Return control knob to “OFF” before checking next igniter.

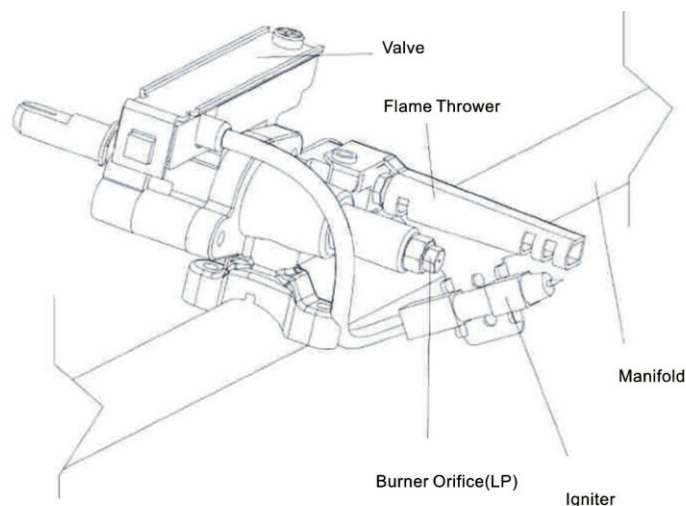

BURNER OPERATION CHECK

NOTE: Upon first assembly the gas lines and burners will be full of air. In order for the burners to light properly the lines must fill with gas. It may require several attempts at lighting the burners before you are successful.

1. With BBQ Grill control knobs in “OFF” position, turn on the Gas supply.
2. Light any burner by pushing its control knob in fully and slowly (3 to 4 seconds) turning it about 1/4 turn to the left (counter-clockwise) until a click is heard. The 3 to 4 second duration should provide enough gas to light the burner. If the burner does not light, immediately return the control knob to “OFF” wait several minutes for the gas to disperse, and repeat the process. After burner lights successfully, turn control knob to “OFF”
3. Repeat process for each control knob/igniter, in turn, ensuring that other knobs are in “OFF” position as you perform each check.
4. If any burners fail to light after several attempts, discontinue gas supply at source and re-inspect for obstructions to gas flow and orifices.

REPLACING HALOGEN BULBS

Your grill is engineered with the convenience of electrical power for illuminating and igniting the grill.

To replace any oven light, follow the instructions below.

CAUTION:

Only replace with 12v / 10 watt halogen bulbs.

WARNING:

To protect from potentially sharp sheet metal and glass, wear gloves and safety glasses during this procedure.

1. Turn all burner control knobs to the OFF position and shut off the gas supply to the grill at the source (tank valve for propane units.)
2. Disconnect supply of external electrical power to the grill.

CAUTION:

Wait for the grill, oven, lens, light bulb, and fixture to cool before proceeding to the next step.



3. Remove screw with a small Phillips screwdriver. And insert a flat head screwdriver into the housing as shown to remove the glass cover. The glass cover may be loose, ensure the cover is properly supported before completely removing the screw.

4. Remove old light bulb by pulling the bulb out of the housing (make sure bulb is cool before removal).

5. Using a soft cloth or paper towel, replace new light bulb into the housing (finger prints left on the bulb may reduce its life). Make sure the metal prongs on the light bulb slip into the openings in the light housing.

6. Replace glass cover and re-snap metal clip into light housing. Replace screw and tighten. To replace the other bulb, follow the same procedure.

CARE AND CLEANING

APPLIANCE MUST BE COMPLETELY COOL WHEN CLEANING. DO NOT SPRAY ANY CLEANER OR LIQUIDS ON THE APPLIANCE WHEN HOT.

The appliance must be cleaned as often as once a month (depending on use) to prevent grease build-up and other food deposits.

INTERIOR

CLEANING THE COOKING GRIDS

After cooking, turn control knobs to “OFF” and let grill cool before attempting to clean your cooking grids. Before first use and periodically it is suggested that you wash the cooking grids in a mild soap and warm water solution. You can use a washcloth or a vegetable brush to clean your cooking grids.

CLEANING THE FLAME TAMERS

Washing the flame tamers after every use is not necessary but periodically it is suggested you wash them in a soap and warm water solution. Use a wire brush to remove stubborn burned on cooking residue. Dry the flame tamers thoroughly before reinstalling.

CLEANING THE BURNERS

IMPORTANT: Gas control knobs should be in the “OFF” position, and fuel line should be disconnected from gas valve manifold. To reduce the chance of FLASHBACK, the procedure below should be followed at least once a month or when your grill has not been used for an extended period of time.

1. Remove burners from grill by carefully lifting each burner up and away from gas valve orific.
2. Wire brush entire outer surface of burner to remove food residue and dirt. Clean any clogged ports with a stiff wire such as an open paper clip.
3. Inspect the burner for damage (cracks or holes) and if such damage is found, order and install a new burner.
4. After installation, check to insure that gas valve orifices are correctly placed inside ends of burner tubes. Also check position of spark electrode.